



**DOSATRON®**

*WATER POWERED DOSING TECHNOLOGY*

---

# SCHEMATICS

## Dosatron Liquid Dispenser **Model # D128R – 7 GPM**

1:200, 1:128, 1:100  
7 – 70 PSI

### **Suggested Installation:**

200 mesh/80 micron water filter prior to unit

One-way check valve downstream from unit for water hammer protection

### **Suggested Maintenance Interval:**

Replace injection seals every 12 months

---

#### **DOSATRON SALES & SERVICE - NORTH & CENTRAL AMERICA**

Dosatron International, Inc.

Phone: 727-443-5404 Service: (800) 523-8499

Fax: 727-447-0591

[www.dosatronUSA.com](http://www.dosatronUSA.com)

**D128R**  
11/03

7 GPM - 1:200 - 1:125 - 1:100  
7 - 70 psi

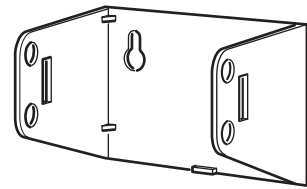
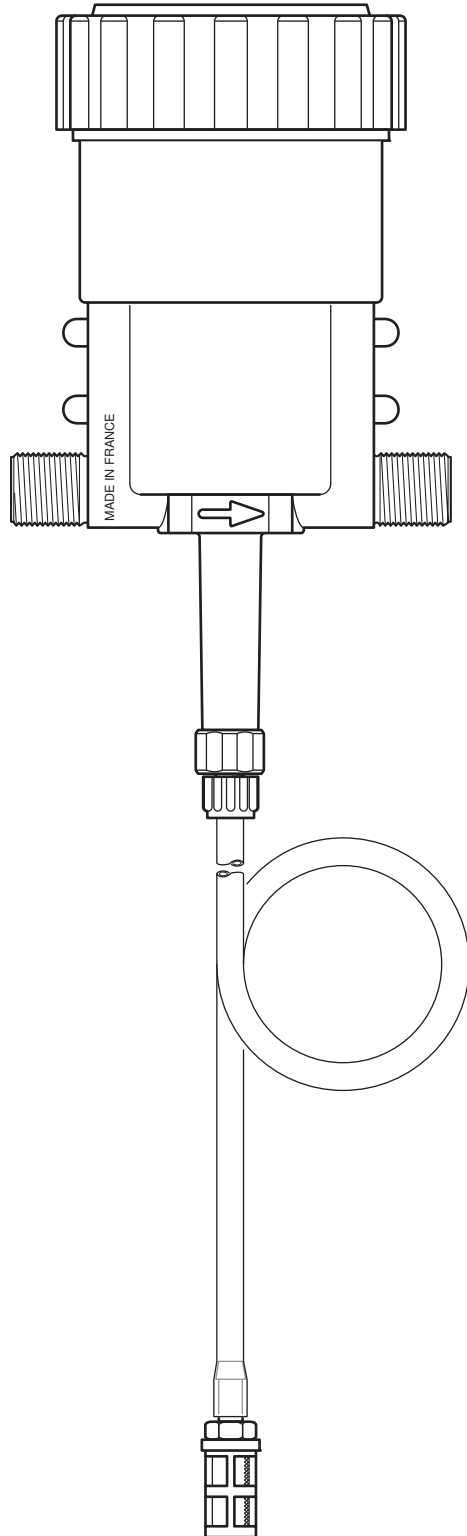

**D128R**  
11/03

7 GPM - 1:200 - 1:125 - 1:100  
7 - 70 psi

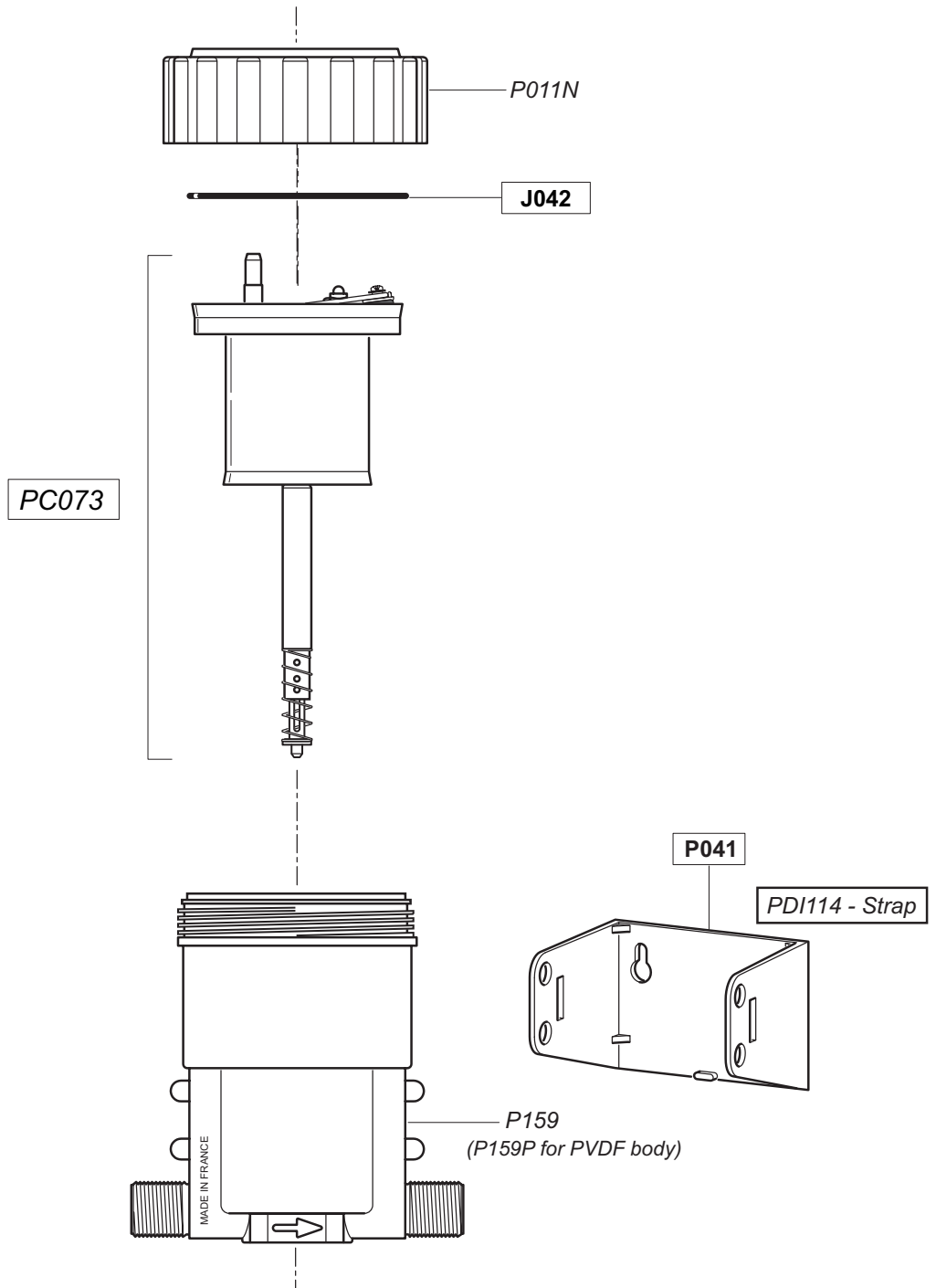

**D128R**  
11/03

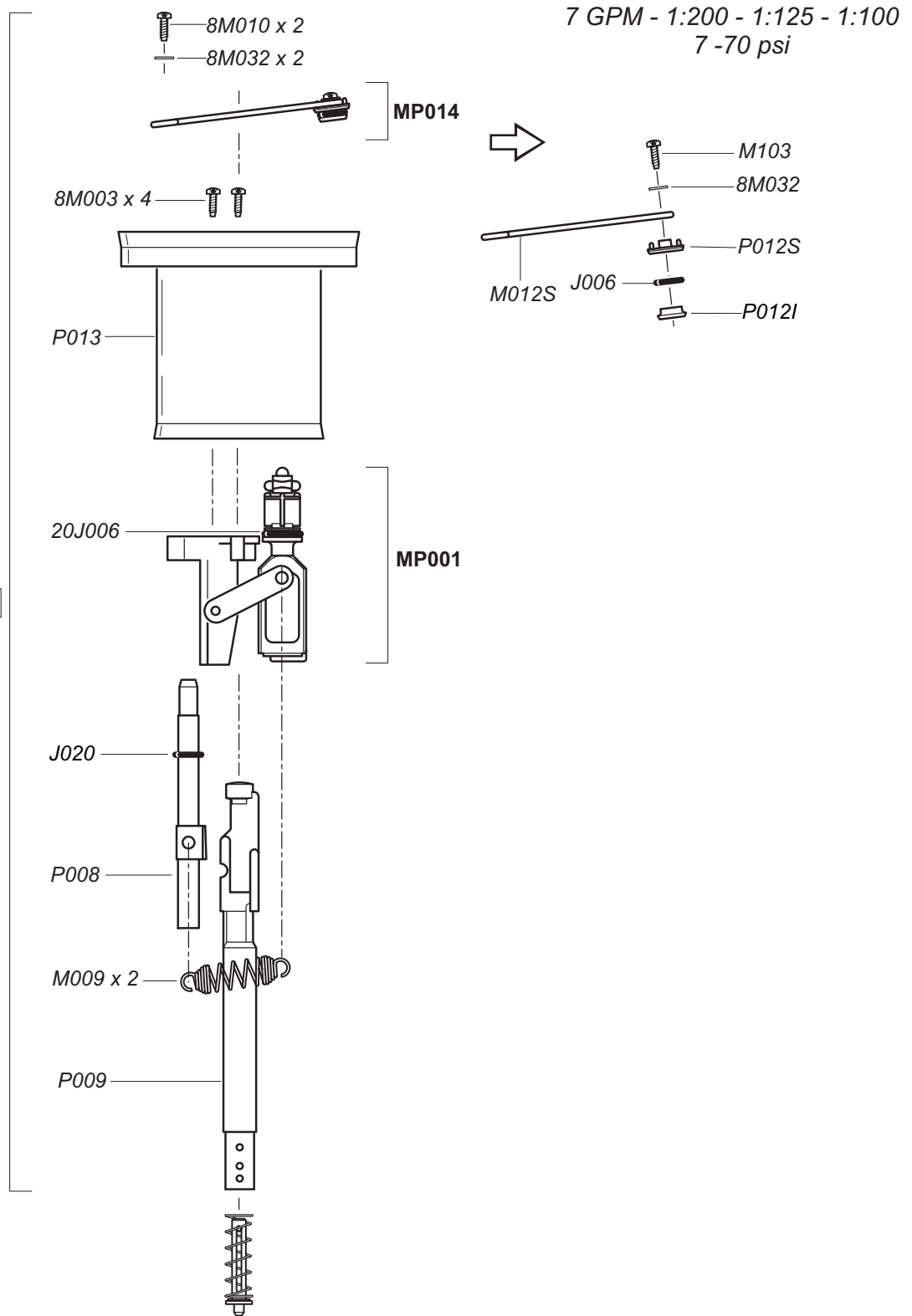

**D128R**  
11/03

7 GPM - 1:200 - 1:125 - 1:100  
7 - 70 psi

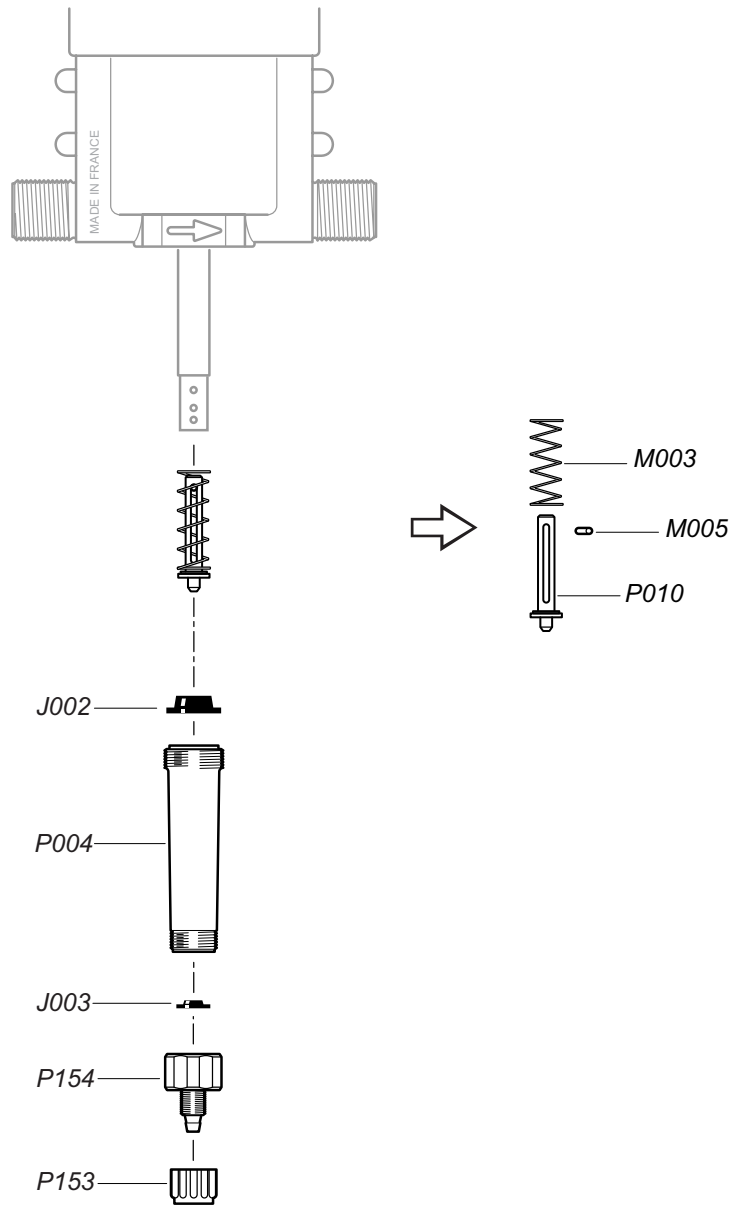

**D128R**  
11/03

7 GPM - 1:200 - 1:125 - 1:100  
7 - 70 psi

